

W. VERLY DispensMate Plus



User Manual

Please read carefully before use, and follow all operating and safety instructions!

Contents	
Safety Instructions.....	1
Components	2
Application and Design.....	3
Materials.....	3
Operating Exclusions	3
Operating Limitations.....	3
Preparing instrument for use	4
Connecting the discharge tube.....	5
Connecting the filling tube	5
Mounting instrument on bottle.....	6
Priming the instrument	6
Priming/Dispensing	7
Setting the volume	8
Cleaning.....	8
Cleaning/replacing the filling valve	10
Cleaning/replacing the discharge valve.....	10
Autoclaving.....	11
Preparation prior to the autoclaving	11
Checking the Volume.....	12
Accuracy	12
Standard deviation	12

Coefficient of variation	12
Trouble Shooting	13
Technical Data	15
Items supplied:	15
Return for Repair	16
Warranty.....	16

Read carefully before use!

Safety Instructions

This instrument may be used with approved hazardous materials, operations, and equipment.

This manual does not purport to address all of the safety problems associated with its use. It is the responsibility of whomever uses this instrument to consult and establish appropriate safety and health practices and determine the applicability of regulatory limitations prior to use.

- a. **Follow the general instructions for hazard prevention and safety regulations, e.g., wear protective clothing, eye protection and gloves.**
- b. Observe the reagent manufacturer's information.
- c. Every user must be acquainted with this Operating Manual before operation.
- d. Use the instrument only for dispensing liquids, with strict regard to the defined Operating Exclusions and Limitations. If in doubt, contact the manufacturer or supplier.
- e. When dispensing, the discharge tube must always

point away from the user or any other person. Avoid splashes. Only dispense into suitable vessels.

- f. Never carry the mounted instrument by the cylinder sleeve or the valve block. Breakage or loosening of the cylinder may lead to personal injury from chemicals.
- g. Never press down the piston when the closure cap is pushed on.
- h. Never remove the discharge tube while the cylinder is filled.
- i. Use smooth gentle movements to operate the piston upwards and downwards.
- j. Use only original manufacturer's accessories and spare parts. Don't carry out technical modifications.
- k. Before use check the instrument for visual damages. In case of trouble (e.g., piston difficult to move, sticking valves or leakage), immediately stop dispensing. Clean the instrument according to the cleaning instructions before any further use of the instrument or contact the manufacturer.

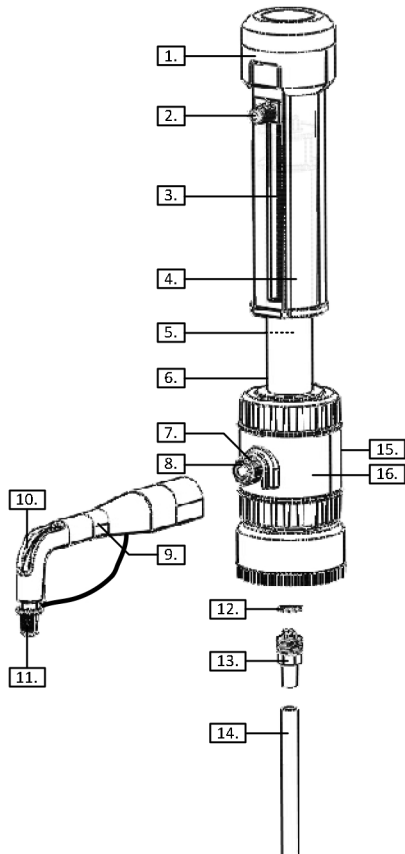

Components

1. Piston seat
2. Volume adjustment knob
3. Scale pointer
4. Cylinder sleeve
5. Piston
6. Glass cylinder
7. Seal
8. Discharge valve
9. Discharge tube sleeve
10. Discharge tube
11. Closure cap
12. Filling seal
13. Filling valve
14. Filling tube
15. Air vent cap
16. Valve block

Application and Design

This instrument is designed for dispensing liquids, observing the following limits:

- 15 to 40 °C of instrument and reagent
- vapor pressure up to 500 mbar
- density up to 2.2 g/cm³

Materials

When the instrument is correctly used, the dispensed liquid comes into contact with only the following chemically resistant materials: Borosilicate glass, PFA, FEP, PTFE, Hastelloy; PP (closure cap).

Operating Exclusions

Never use this instrument for

- liquids attacking FEP, PFA, PTFE or Hastelloy.
- liquids attacking borosilicate glass (e.g., hydrofluoric

acid)

- liquids which are decomposed catalytically by Hastelloy (e.g., H₂O₂)
- explosive liquids .
- suspensions as solid particles may clog or damage the instrument.

Operating Limitations

Concentrated hydrochloric acid and concentrated nitric acid, chlorinated and fluorinated hydrocarbons, or liquids which form deposits may make the piston difficult to move or may cause jamming.

When dispensing flammable media, make provisions to avoid static charging, e. g., do not dispense into plastic vessels; do not wipe instruments with a dry cloth.

Warning!

If there is a sign of a potential malfunction (e.g., piston difficult to move) never use force. Immediately stop dispensing and follow cleaning instructions or contact the manufacturer.

Note:

Compatibility of the instrument for this special application (e. g., trace material analysis) must be checked by the user or contact the manufacturer.

Preparing instrument for use

Attention!

The adapters supplied with the instrument are made of polypropylene (PP), and can only be used for media which does not attack PP .

Warning!

Wear protective clothing, eye protection and gloves.
Follow all Safety Instructions and observe the Operating Exclusions and Limitations.

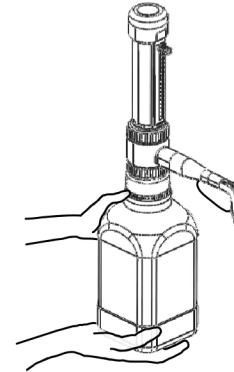

Figure 1

Warning!

Always wear protective gloves when touching the instrument and the bottle, especially when using dangerous liquids. Carry the mounted instrument only as shown in figure.

Connecting the discharge tube

Warning!

Do not use any other type of discharge tube.
Never use damaged or deformed discharge tubes.

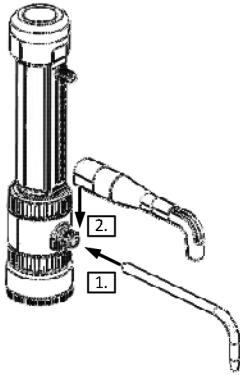

Figure 2

1. Firmly tighten the discharge valve with tools.
2. Push the discharge tube as far as possible into the discharge valve.

Connecting the filling tube

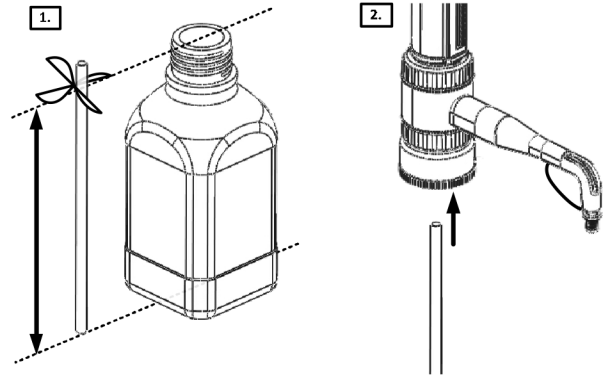

Figure 3

1. Cut off the bottom of the filling tube diagonally.
2. Push the filling tube into the valve block as far as possible – with the diagonal end down.

Mounting instrument on bottle

The instrument can be screwed directly onto a GL 45 screwthread. For other bottles, use the accompanying adapters.

Attention!

The adapters supplied with the instrument are made of polypropylene (PP), and can only be applied for media which do not attack PP.

Priming the instrument

Attention!

For small bottles use a bottle stand to prevent tipping over.

Warning!

Reagent may drop off the discharge tube and closure cap.

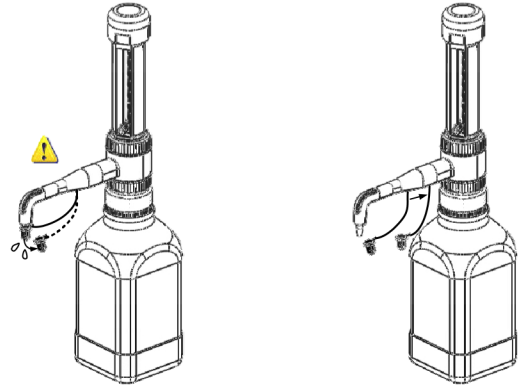

Figure 4

- Hold the discharge tube and carefully remove the closure cap.
- Slide the closure cap backwards on the tube support, away from the discharge tube opening.

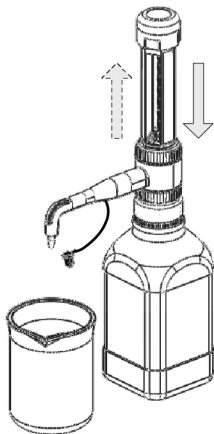

Figure 5

1. Hold an appropriate collecting vessel under the discharge tube opening.
2. Gently pull the piston up, then press it down rapidly.
3. Repeat this procedure until most of the air bubbles in the glass cylinder and discharge tube have been removed.

Note:

Before using the instrument for the first time, ensure it is rinsed carefully or discard first few samples dispensed.

Priming/Dispensing

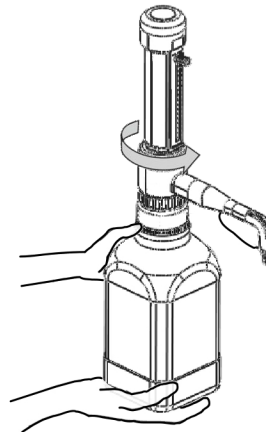

Figure 6

Warning!

Follow all Safety Instructions and observe the Operating Exclusions and Limitations. The discharge tube must always point away from the user or any other person. Never press down the piston when the closure cap is pushed on. Reagent may drop off the discharge tube and closure cap.

Setting the volume

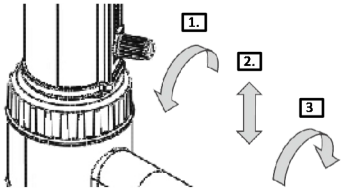

Figure 7

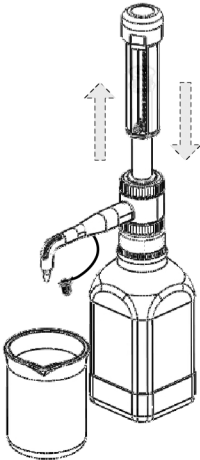

Figure 8

- Hold an appropriate collecting vessel under the discharge tube opening.
- Pull the piston up slowly and evenly to the upper stop to draw reagent into the glass cylinder.
- Push the piston down gently and evenly to dispense the reagent into the vessel.

Attention!
After use, always leave the piston in the down position.

Cleaning

The instrument must be cleaned in the following situations to assure correct operation:

- if the piston becomes difficult to move
- after dispensing liquids which form deposits
- before changing the reagent
- prior to long term storage
- should liquid have accumulated in the closure cap
- prior to sterilization
- before replacing the valves

Warning!

Follow all Safety Instructions. The glass cylinder, valves, filling and discharge tubes contain reagent. Wear protective clothing, eye protection and appropriate hand protection.

Note:

Never change the pistons of the instruments!

1. Push on the closure cap.
2. Empty and unscrew the instrument from the bottle and lift the instrument so that the filling tube is out of the liquid but still in the bottle.
3. Carefully tap the filling tube against the bottle from the inside so that the reagent runs back into the bottle.

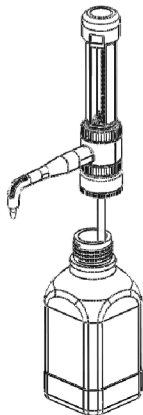

Figure 9

4. Remove the closure cap, and dispense the remaining reagent into the bottle by repeated piston operation.
5. Mount the instrument onto another bottle filled with an appropriate cleaning solution.
6. Flush the instrument.
7. Empty the bottle, flush it and fill it with water. Repeat step 6 and 7.
8. Empty the instrument.
9. Unscrew the piston seat (1).
10. Carefully pull the piston (5) out of the glass cylinder (6) by pulling on the piston seat only.
11. Carefully remove deposits at the edge of the glass cylinder with a screw driver. Clean piston and cylinder with a bottle-brush.
12. Carefully reassemble the instrument in the reverse order. Flush instrument with distilled water.

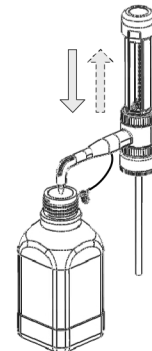

Figure 10

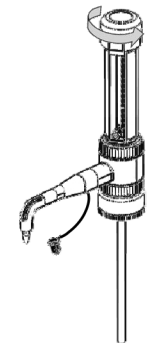

Figure 11

Note:

Insert the piston straight into the cylinder, not at an angle.

Cleaning/replacing the filling valve

1. Follow all cleaning instructions.
2. Remove the filling tube.
3. Unscrew the filling valve using the mounting tool. Remove the valve with its sealing washer. Make sure the sealing washer does not remain in the valve block.
4. Rinse the filling valve in the cleaning solution, and clean with soft brush. Should valve ball stick, push into filling opening of valve with pointed instrument, and release valve ball.
5. Screw the cleaned/new filling valve together with its sealing washer into the valve block and tighten it firmly using the mounting tool.

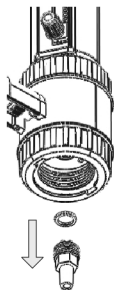

Figure 12

Cleaning/replacing the discharge valve

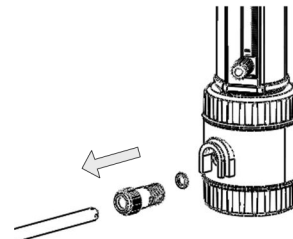

Figure 13

1. Follow all cleaning instructions.
2. Unscrew the discharge tube.
3. Remove valve locking ring.
4. Unscrew the discharge valve using the mounting tool. Remove the valve with its sealing washer. Make sure the sealing washer does not remain in the valve block.
5. Rinse the discharge valve in the cleaning solution, and clean with soft brush. Should valve ball stick, push into filling opening of valve with pointed instrument (e.g., disposable pipette tip), and release valve ball.
6. Screw the cleaned/new discharge valve together with its sealing washer into the valve block and tighten it firmly using the mounting tool.

- Slide on the valve locking ring making sure the two prongs properly align with the notches.

Autoclaving

This instrument withstands steam sterilization at 121 °C, 2 bar absolute (15 psi) for 20 minutes in accordance with widely used guidelines. It is the user's responsibility to ensure effective autoclaving.

Preparation prior to the autoclaving

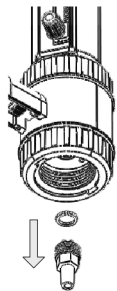

Figure 14

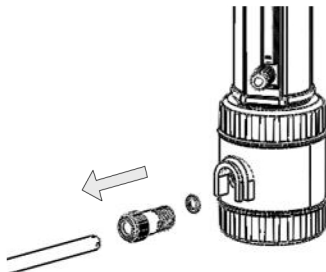

Figure 15

- Clean the instrument before sterilization.
- Remove the discharge tube (10) with removed closure

cap (11), filling tube (14), and put all parts on a towel.
Avoid contact with hot metal surfaces.

- Lay the instrument **with piston in down position** on the towel.
- Autoclave all parts.

Note:

Allow to cool down in the closed autoclave to avoid deformation through too rapid cooling. After every autoclaving, inspect all parts for deformities or damage. If necessary, replace them. Do not reassemble the instrument until it has cooled down to room temperature (cooling time approx. 2 hours).

Mounting tool can be steam sterilized at 121 °C.

Checking the Volume

The accuracy and coefficient of variation of the instrument are determined gravimetrically as follows:

- Set to the nominal volume.
- Dispense distilled H₂O.
- Weigh the dispensed quantity on an analytical balance.
- Calculate the dispensed volume taking the temperature into account.
- Perform at least 10 dispensing and weighing operations.
- Calculate the accuracy (A%) and the coefficient of variation (CV%) by means of the formular used in statistical quality control. The proceeding is described e.g., in DIN EN ISO 8655-6. Observe the operating manual of the balance manufacturer and the corresponding standards.

Calculations (for the nominal volume)

$$\text{Mean value } \bar{x} = \frac{\sum x_i}{n},$$

x_i = results of weighings
 n = number of weighings

$$\text{Mean volume } \bar{V} = \bar{x} \cdot Z,$$

Z = correction factor

(e. g. 1.0029 µl/mg at 20 °C, 1013 hPa)

Accuracy

$$A\% = \frac{\bar{V} - V_0}{V_0} \cdot 100$$

V_0 = nominal volume

Standard deviation

$$s = Z \cdot \sqrt{\frac{\sum (x_i - \bar{x})^2}{n - 1}}$$

Coefficient of variation

$$CV\% = \frac{100s}{\bar{V}}$$

Trouble Shooting

Problem	Possible cause	Corrective action
Piston difficult to move	<ul style="list-style-type: none"> - Formation of crystals, dirty 	<ul style="list-style-type: none"> - Stop dispensing immediately. Loosen piston by circular motion, but do not disassemble. Follow all cleaning instructions.
Filling not possible	<ul style="list-style-type: none"> - Volume adjusted to minimum setting - Sticking filling valve 	<ul style="list-style-type: none"> - Set to required volume. - Clean the filling valve. If necessary replace the valve with sealing washer.
Instrument does not dispense liquid	<ul style="list-style-type: none"> - Discharge tube closure cap pushed on - Discharge tube not firmly connected or damaged 	<ul style="list-style-type: none"> - Remove closure cap. - Push on the closure cap. Hold the piston in place, and push the original manufacturer's discharge tube on firmly. Replace a deformed or damaged discharge tube.
Air bubbles in the instrument	<ul style="list-style-type: none"> - Reagent with high vapor pressure has been drawn in too quickly 	<ul style="list-style-type: none"> - Slowly draw in reagent.

	<ul style="list-style-type: none"> - Seal not inserted, knurled locking nuts not firmly connected - Air not expelled from the instrument - Filling tube not firmly connected or damaged - Valves dirty, not firmly installed or damaged 	<ul style="list-style-type: none"> - Double check that seal (12) is in place, and that the knurled locking nuts at the discharge tube are firmly seated and finger tight. - Priming the instrument. - Push the filling tube on firmly. If necessary cut off approx. 1 cm of tube at the upper end and reconnect it or replace filling tube. - Cleaning procedure. Tighten the valves using the mounting tool. If necessary, replace the valves and sealing washers.
<p>Dispensed volume is too low</p>	<ul style="list-style-type: none"> - Discharge tube not firmly connected or damaged - Filling tube not firmly connected or damaged - Valves not firmly installed or damaged - Sticking filling valve 	<ul style="list-style-type: none"> - Push the original manufacturer's tube on firmly. - Cleaning procedure. Push the filling tube on firmly. If this does not suffice, cut off approx. 1 cm of tube at the upper end and re-connect it or replace filling tube. - Clean the instrument. Tighten the valves using the mounting tool, if necessary replace the valves and sealing washers. - Clean or replace discharge tube, if necessary.

Technical Data



20 °C
EX

Volume ml	Graduation ml	A* $\leq \pm$		CV* \leq		Cat. No.
		%	μ l	%	μ l	
0.5 - 5	0.1	0.5	25	0.1	5	D105
1 - 10	0.2	0.5	50	0.1	10	D110
2.5 - 25	0.5	0.5	125	0.1	25	D125
5 - 50	1.0	0.5	250	0.1	50	D150

* Error limits (A = Accuracy, CV = Coefficient of variation) relative to the nominal capacity (maximum volume) indicated on the instrument, obtained at equal temperature (20 °C) of instrument, ambience and dist. water, and with smooth operation.

Items supplied:

Operating manual, 1 discharge tube, 1 mounting tool, 1 filling tube and adapters of PP of the following sizes:

Nominal vol. tube	Adapter, PP	Filling
0.5 – 5		300mm
1 - 10	GL 25, GL 28, GL	
2.5 – 25	32, GL 38, S40	
5 - 50		

Return for Repair

Attention:

For safety reasons only clean/decontaminated instruments can be checked/repaired.

- Therefore: Clean and decontaminate the instrument carefully.

Return shipment has to be effected at the risk and cost of the sender.

Warranty

As provided by law, any and all warranties are null and void if the product has been misused, modified or repaired by unauthorized personnel, if the defects are caused by negligence (instruction manual, maintenance) or by normal wear and tear. Use only original manufacturer's accessory/spare parts.

For conditions and extent of warranty refer to our General Conditions of Sale.



For additional help, please contact one of our authorized dealers::



SoCal BioMed, LLC
4695 MacArthur Court, 11th Floor
Newport Beach, CA 92660
Phone: (424) 400-2340
Email: info@socalbiomed.com
www.socalbiomed.com